

Height Restriction Barrier



A height restriction barrier installed at a wide junction on to a mainroad with the height restriction manufactured to clients requirements. Entirely made up of rolled hollow sections to give the barrier added strength and take heavy impacts.

Hinged at one end to allow authorized tall vehicles to pass.

Hinges inverted inwards preventing the barrier from being lifted off the post. Each hinge can be adjusted for perfect level span.



A high quality cost effective height restriction barrier designed to the customers requirements. Made up of high grade steel and diagonally braced to facilitate large spans and give extra strength. Hinged to temporarily allow tall vehicles to enter and exit when authorised.

This specialized system is formed at JPK's manufacturing facility and installed by JPK nationwide. All steel sections and fittings are galvanised providing long term maintenance free protection from corrosion.

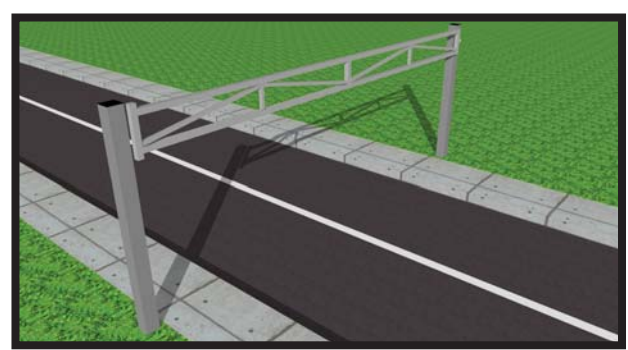
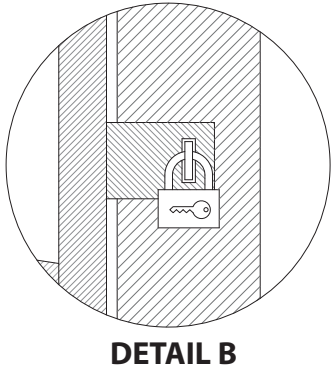
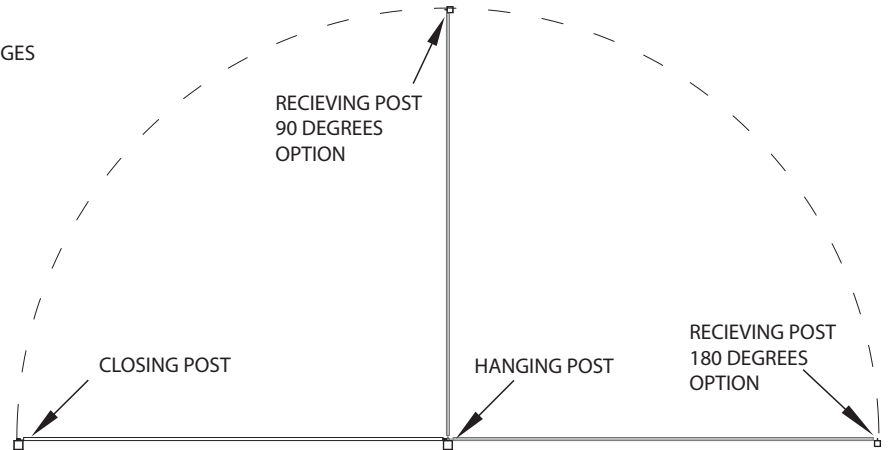
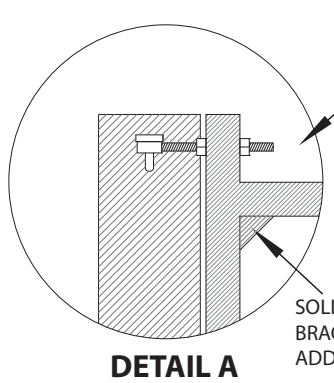
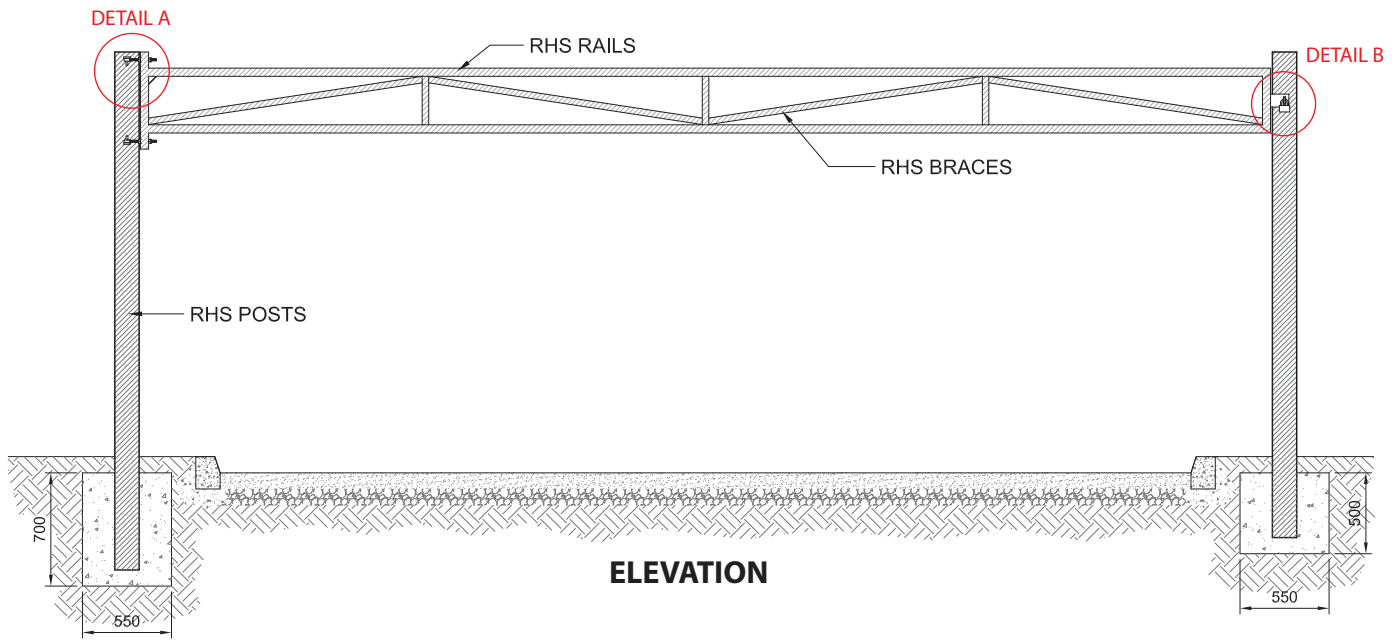

Steel Sections Galvanised to EN ISO 1461

JPK
Est. 1975
Fencing Systems

website : www.jpk.ie
email : info@jpk.ie
telephone : +353 91 798 146

FOR LIFELONG
COLOUR
POWDER
COAT IT
POWDER COATED TO BS EN 13435:2005

